

SERVICE MANUAL

FOR

**BROTHER MODEL LT2-B835-400
-500**



**BROTHER INDUSTRIES, LTD.
NAGOYA, JAPAN**

From the library of: Superior Sewing Machine & Supply LLC

NAME OF MAJOR COMPONENTS

< LT2 – B835 – 500 >

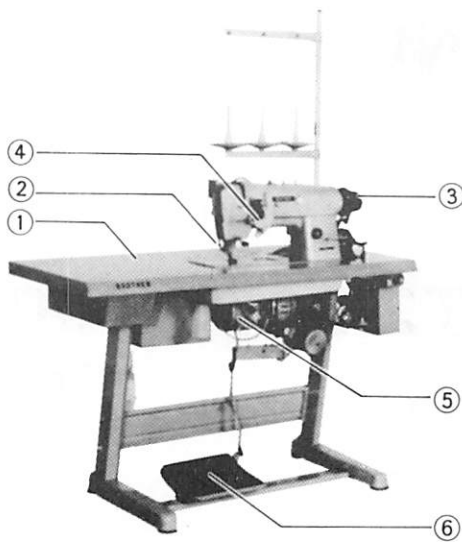

- ① Table
- ② Thread wiper
- ③ Synchronizer
- ④ Flip-up device
- ⑤ N. P. Motor
- ⑥ Treadle pedal

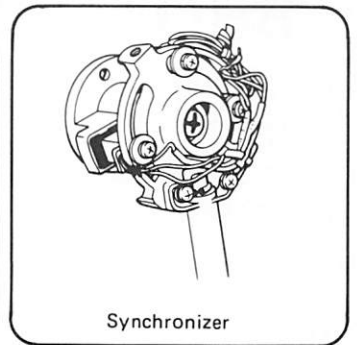
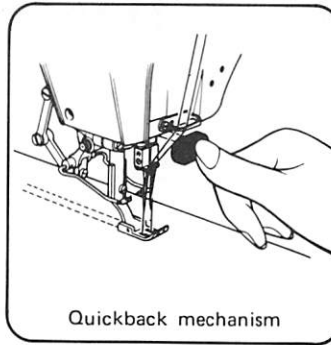
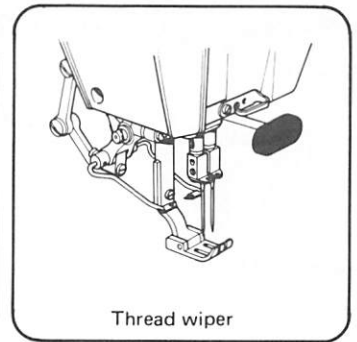
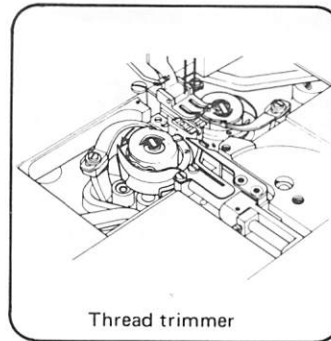

SPECIFICATIONS

Thread trimmer specifications

	– 400	– 500
Thread trimmer	Solenoid	Pneumatic
Tension releaser	Mechanical	Pneumatic
Thread wiper	Solenoid	
Quick reverse	Solenoid	Pneumatic
Presser foot lift	–	Pneumatic

Machine head specifications

Sub-class	– 3	– 5
Use	Thin & Medium	Thick
Max. sewing speed (s.p.m.)	3000	
Max. stitch length (mm)	5	
Height of presser foot (mm)	7	
Height of feed dog (mm)	1	1 ~ 1.2
Needle gauge	1/8", 5/32", 3/16", 1/4", 5/16", 3/8"	
Needle	DP x 5	
Oiling system	Semi automatic lubrication	
Power source	1/2 Hp NP motor	
Rotary hook	Rotary hook with thread loosening avoiding spring	

<NOTE>

This service manual indicates only those items in which B835 with thread trimmer is different from B832 with thread trimmer.

Therefore, for other items than these, please refer to the service manual for B832 with thread trimmer.

ADJUSTING PROCEDURE

1 ROCK CRANK

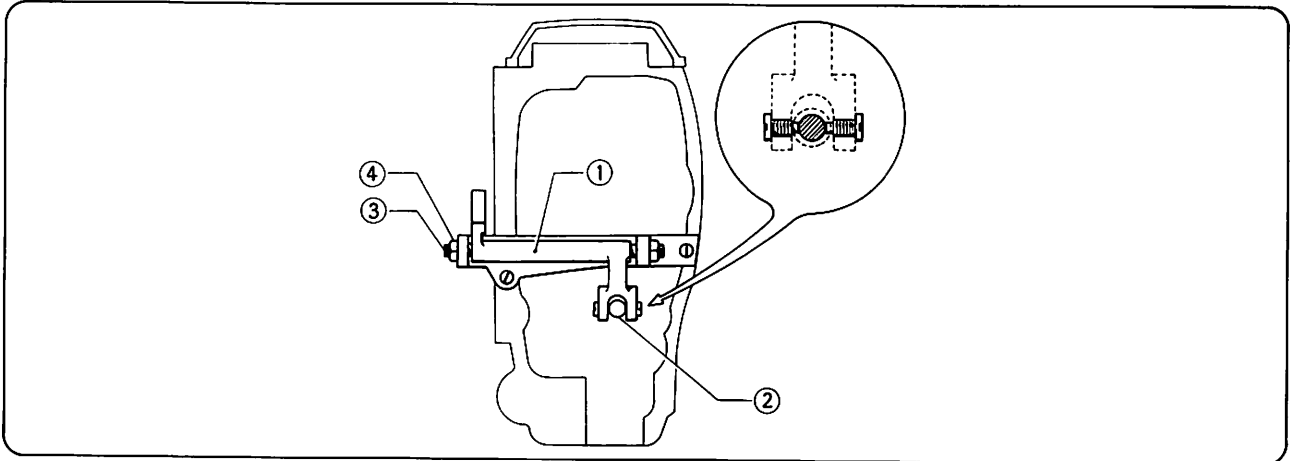

1. Adjust the forked part of rock crank ① to be located in the center of slide shaft ② by turning screw ③ as shown in Figure.
 2. After this adjustment, tighten nut ④ in such a way that rock crank ① can be operated smoothly, without becoming loose.
- * If rock crank cannot be moved smoothly, the exchange of needle bar flip-up will become worse.

2 PUSH LEVER POSITION

1. Push stud ② in the arrow direction in such a way that the operation of push lever ① can be made lightly, and stop loosening in the horizontal direction, and then tighten screw ③ to the seat of screw.
- * If the looseness is big in the horizontal direction the position of stop lever gets changed and the exchange of needle bar flip-up becomes bad, also if the operation torque is heavy, the same thing happens.

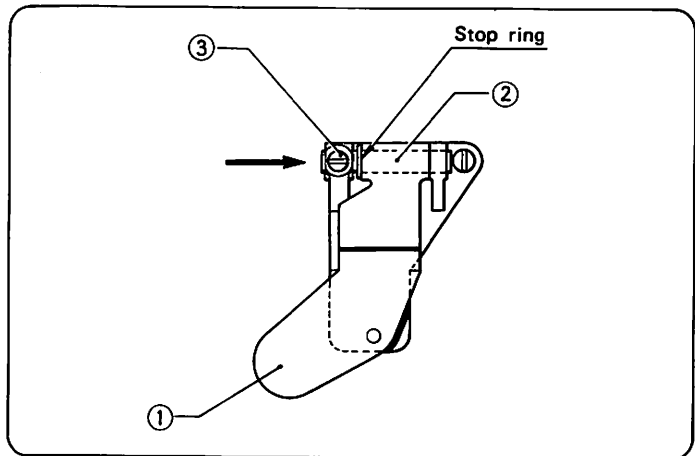

3 SLIDE SHAFT

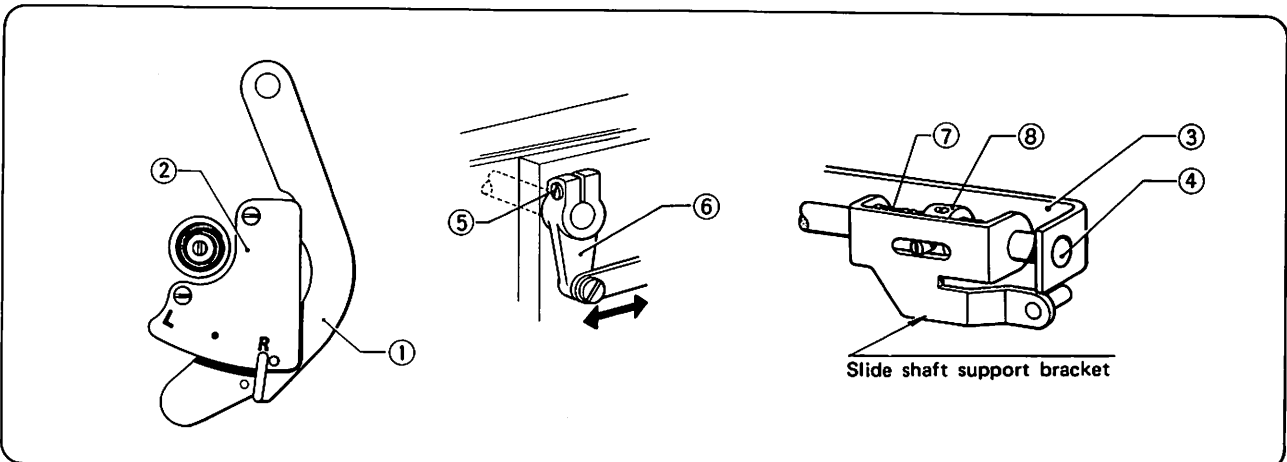

1. Set stop lever ① to R position of flip-up holder plate ②.
 2. Make adjustment by loosening screw ⑤ and moving lever shaft arm ⑥ right and left so that the end of slide plate supporter ③ meets with the end of slide shaft ④.
- * If the position of slide shaft is not proper, it will be impossible to adjust spring ⑦ and set collar ⑧.

4 SLIDE SHAFT SUPPORT BRACKET

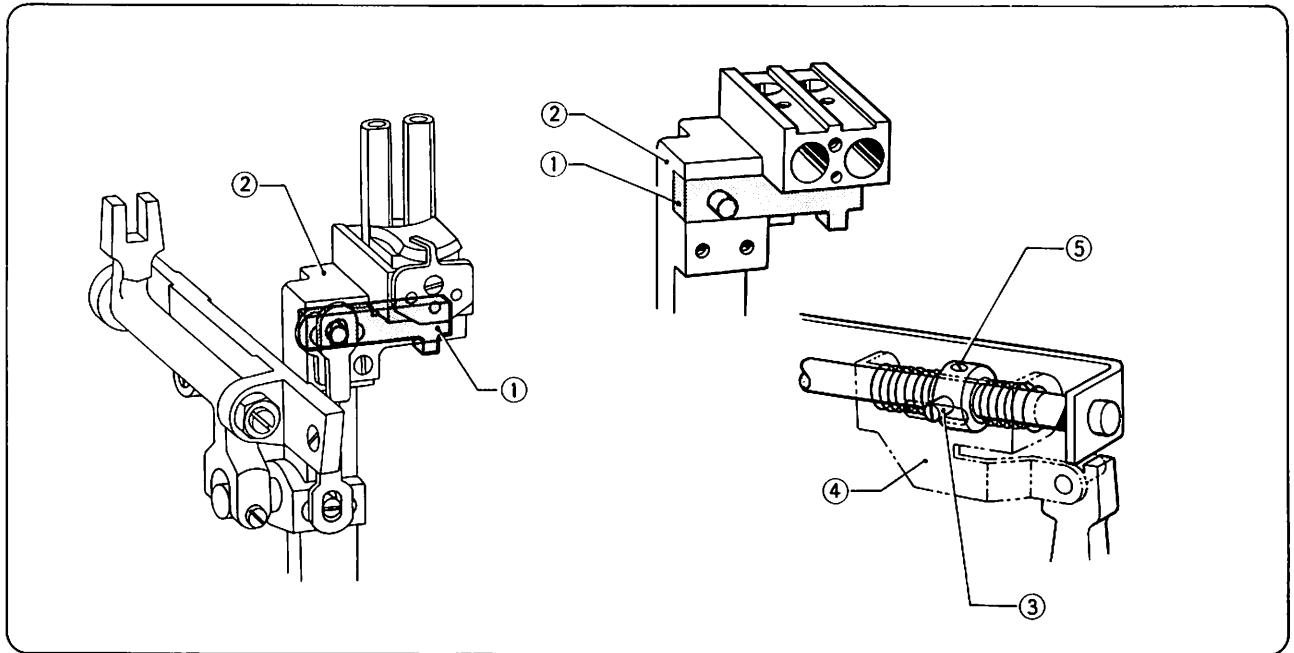

1. Set stop lever to the mark of flip-up holder plate.
 2. Align the left end of slide block ① with the left end of needle bar support ②.
 3. Tighten screw ③ through the hole of slide plate ④, and tighten screw ⑤.
- * If this position is not proper, release pin and needle bar will be broken.

5 LEVER SHAFT ARM SPRING PRESSURE

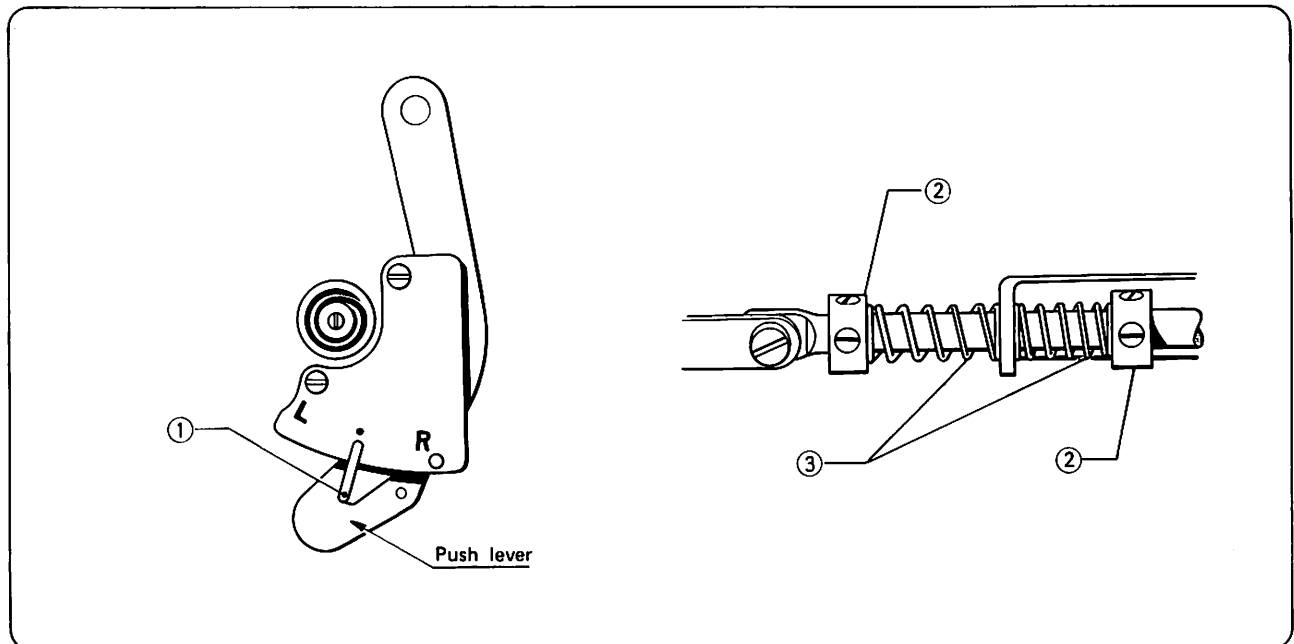

1. When stop lever ① is released from L or R position, stop lever ① must stop at the position marked in the center as shown in Figure.
2. When stop lever ① is set at L or R position, set collar ② must be fixed at where set collar ② lightly touches spring ③.
3. The pressure of spring L and R are same.
4. If stop lever ① does not stop at the position marked in the center, readjust the pressure of spring ③.

6 NEEDLE BAR PUSHER

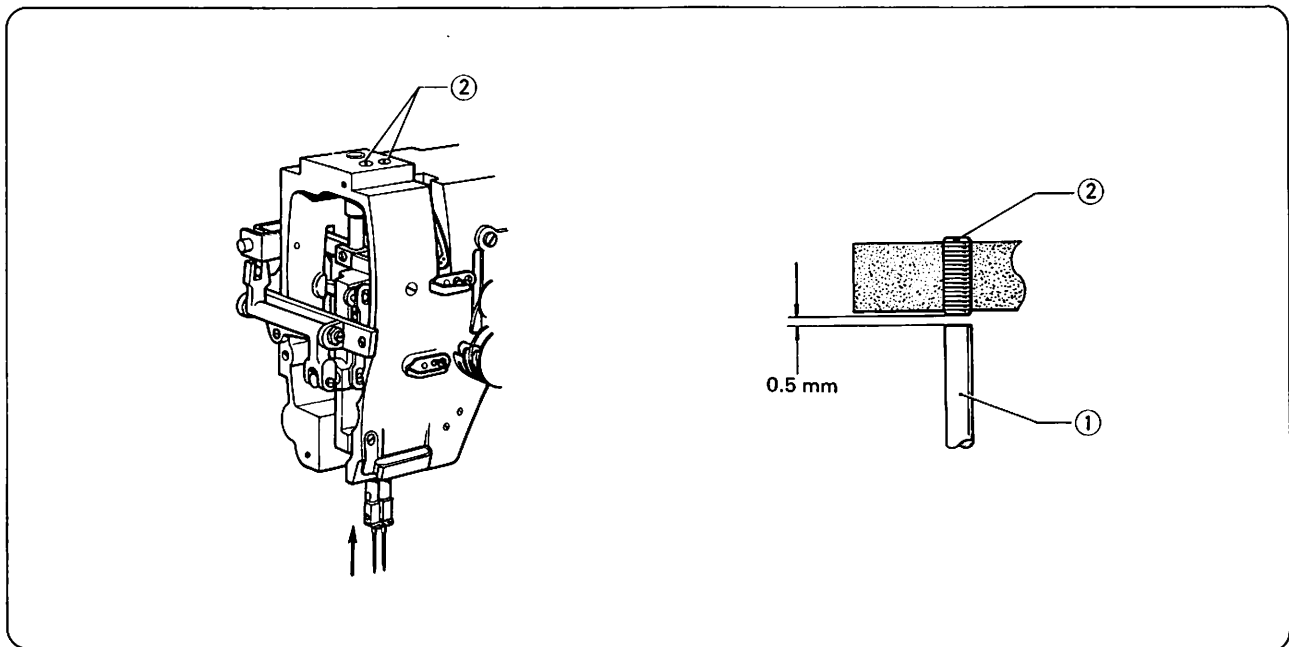

1. When needle bar ① is at the highest position, adjust so that the clearance between the lower end of needle bar pusher ② and the upper end of needle bar ① comes to be 0.5mm by turning needle bar pusher ②.

7 NEEDLE AND ROTARY HOOK TIMING

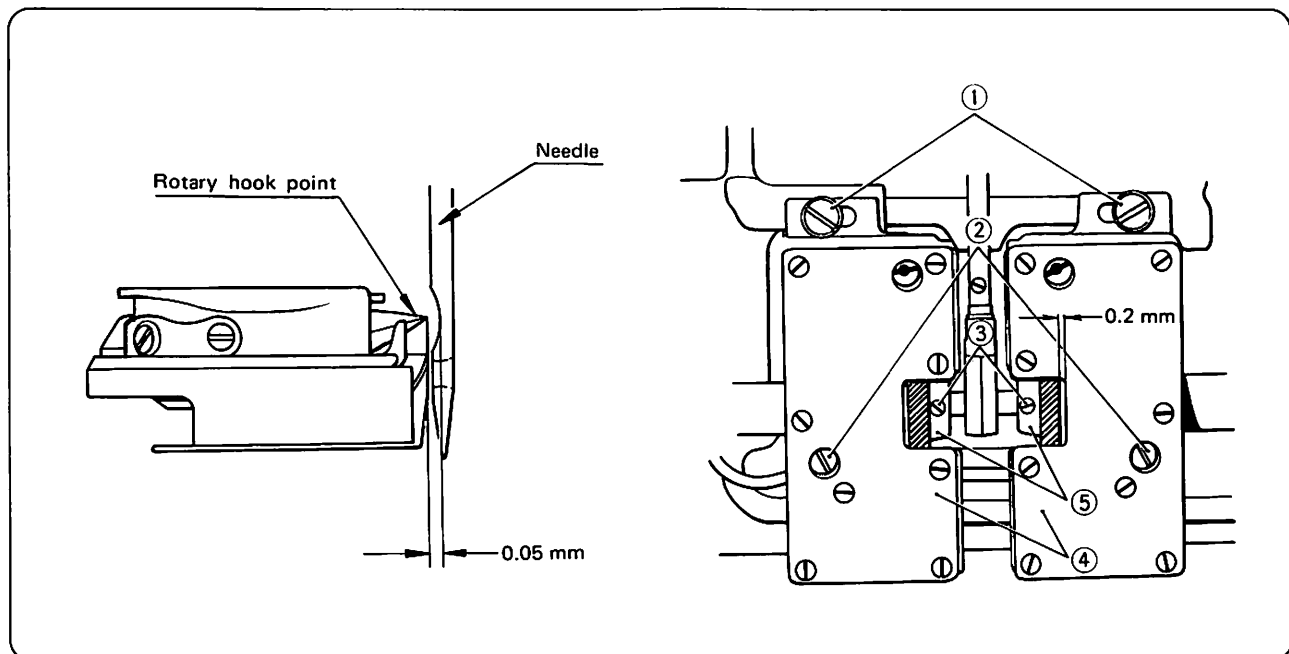

(1) Clearances between needles and rotary hook points

1. Loosen screws ① ② and ③ and move rotary hook base ④ until the clearance between needle and rotary hook point becomes about 0.5mm.
2. When the clearance between needle and rotary hook point has been adjusted, adjust the clearance between rotary hook base ④ and spiral gear end ⑤ to about 0.2 mm.

* Tighten screws ③ in such a way that its contact remains unchanged.

(2) Clearances between rotary hook and needle plate

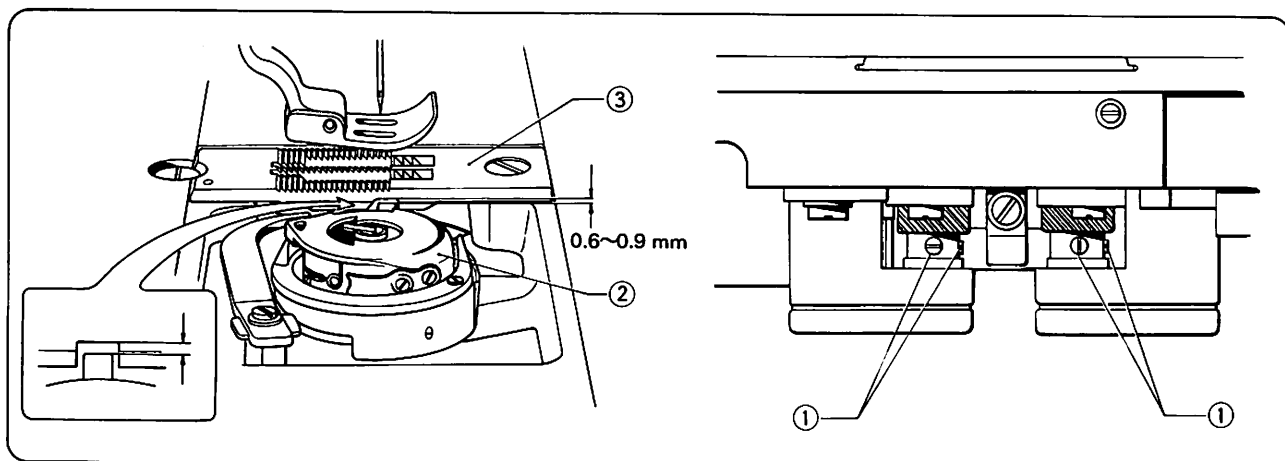

1. Make adjustment by loosening screws ① and moving rotary hook ② up and down so that the clearance between rotary hook ② and needle plate ③ becomes 0.6~0.9mm.

(3) Needle bar rise, needle bar height

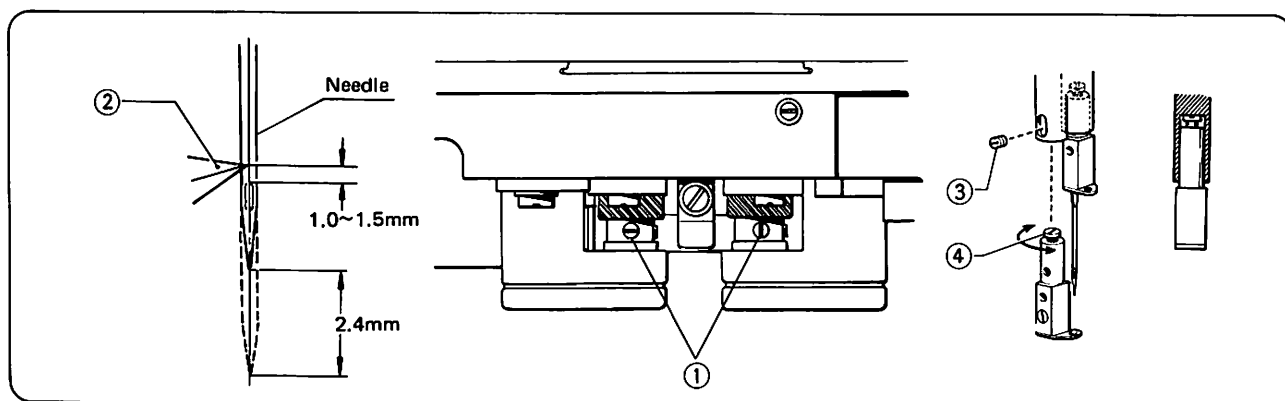

1. Set the feed at position "2".
2. Loosen screws ①, and adjust so that rotary hook point ② must be at the center of needle when needle rises 2.4mm from the lowest position.
3. Set the feed at position "0".
4. Remove screw ③, and adjust so that the distance between upper end of needle hole and rotary hook point is 1.0~1.5mm by turning screw ④ when rotary hook point is at the center of needle.

(4) Clearances between rotary hook and opener

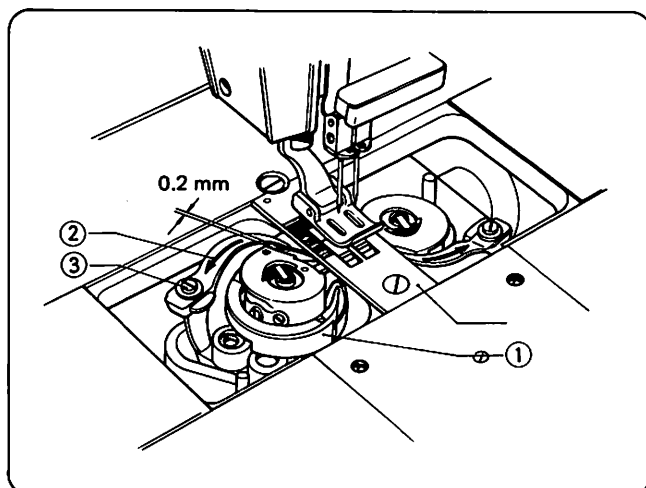

1. The clearance between rotary hook ① and opener ② must be about 0.2 mm when opener ② is fully pulled back in the arrow direction, otherwise loosen screw ③ and adjust the clearance.

**8 ANTI-SPINNING SPRING,
KNIFE DRIVING CAM**

(1) Anti-spinning spring

Anti-spinning spring for LT2-B835 uses a little bit weak spring as compared with the one for LT2-B832, because the resistance of lower thread passage in the bobbin case is bigger in the case of LT2-B835 than LT2-B832.

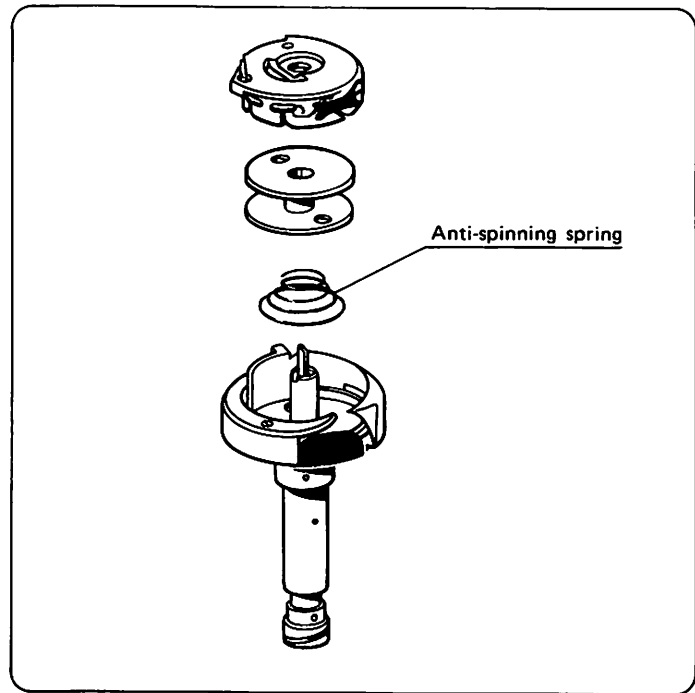

(2) Knife driving cam

In case of B835-405 for thick material, the shape of knife returning part has been specially designed for anti-spinning of bobbin at time of thread trimming so as not to supply lower thread.

Another specifications of B835 with thread trimmer is same as LT2-B832 with thread trimmer.

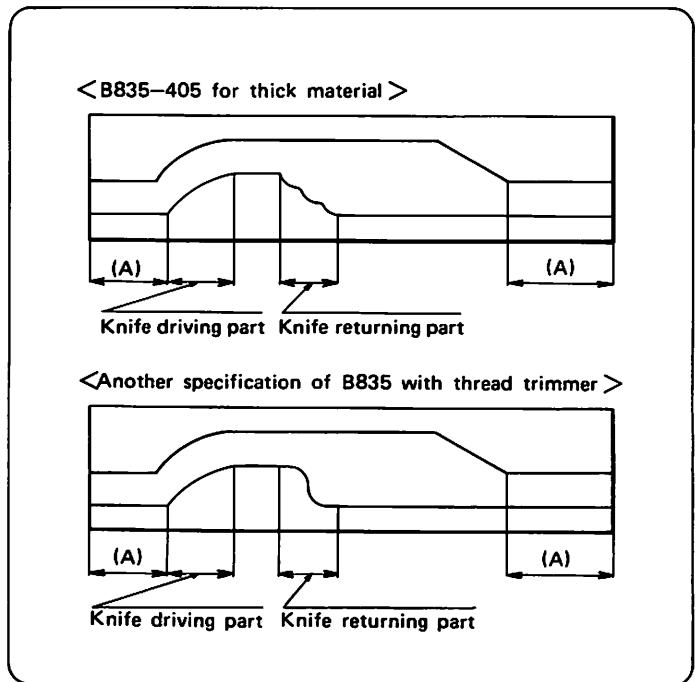



BROTHER INDUSTRIES, LTD.
HEAD OFFICE: NO. 35, 9-CHOME HORITA-DORI MIZUHO-
NAGOYA, JAPAN
TELEX: BROTHER J59743
ESTD 1932
Printed in Japan

From the library of: Superior Sewing Machine & Supply LLC